

Power Terminal, Lug-to-Tunnel, 800 A

Data Solutions

NUMĂR DE CATALOG

SBLT-800

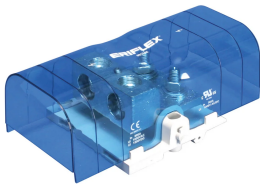

CERTIFICATIONS



CARACTERISTICI

Tinned copper block allows for copper or aluminum conductor connections

Accessible studs and tunnels allow for easy connection of nVent ERIFLEX Flexibar and other conductors

Design allows for visual inspection of conductor and confirmation of connection

Voltage detection and measurement connection

Adjustable transparent cover

Modular snap-together blocks for building multi-pole power blocks

Easily clips onto DIN rail or mounts to panel with screws

SBLEC Power Terminals Fixing Accessory required for direct panel mount

RoHS compliant

Halogen free

ATTRIBUTE PRODUS

Article Number: 561146

Material: Copper; Thermoplastic

Finish: Tinned

Max Current Rating, IEC: 1250A

Max Current Rating, UL/CSA: 760A

Short Term Withstand Current (Icw) 1s: 57.6kA

Peak Short Circuit Current (Ipk): 75kA

Short Circuit Current Rating (SCCR): 100kA

Max Working Voltage, IEC (Ui): 1000; 1500

Max Working Voltage, UL (Vin): 1000

Number of Stud Connections: 2

Stud Connection Conductor Width: (2) 20 – 40 mm; (1) 50 – 80 mm

Stud Connection Compact Stranded Wire Size: (2) 35 – 300 mm²

Stud Connection Wire Size: (2) #1 - 500 kcmil

Number of Tunnel Connections: 2

Tunnel Connection Compact Stranded Wire Size: (2) 95 – 240 mm²

Tunnel Connection Wire Size - Ferrule: (2) 50 – 185 mm²

Tunnel Connection Wire Size: (2) 3/0 – 500 kcmil

Depth (D): 75mm

Height (H): 205.7mm

Width (W): 115mm

A: 108mm

Unit Weight: 1.09kg

Certification Details: UL® 1059

Flammability Rating: UL® 94V-1

Complies With: IEC® 60947-7-1

DETALII SUPLIMENTARE DESPRE PRODUS

Power terminal connections are interchangeable and can be used as line side or load side connections.

Design Guideline for Distribution Blocks, Power Blocks and Power Terminals

Derating according to Ambient* Temperature (°C) to maintain working temperature of 85°C

Ambient Temperature (°C)	30°	35°	40°	45°	50°	55°	60°	65°	70°	75°
Derating Coefficient (d)	1	1	1	0.94	0.88	0.82	0.75	0.67	0.58	0.47

*environment around the terminal blocks inside the enclosure

DIAGRAMS

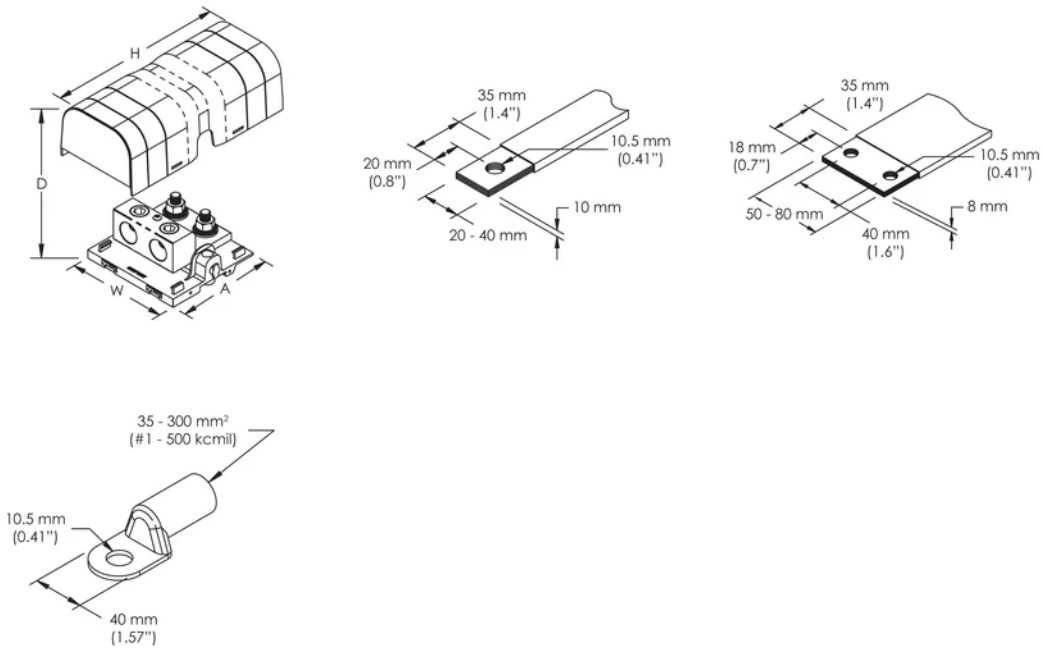

AVERTIZARE

Produsele nVent trebuie instalate și utilizate numai așa cum este indicat în fișele de instrucțiuni și materialele de formare ale nVent. Fișele de instrucțiuni sunt disponibile pe www.nvent.com și de la reprezentantul dvs. de servicii clienți nVent. O instalare incorectă, o utilizare abuzivă, o aplicare greșită sau orice altă lipsă de respectare completă a instrucțiunilor și avertismentelor nVent poate duce la defectarea produsului, la deteriorarea proprietății, la răni corporale grave și moarte și/sau poate anula garanția dvs.



Portofoliul nostru puternic de mărci:

CADDY ERICO HOFFMAN ILSCO SCHROFF TRACHTE